

# **TECHNICAL DRAWING PACK**

---

These drawings show all elements of the design and are to signed off prior to production.

It is important that all details are carefully checked and understood by yourselves as they will be used for manufacture.

---

**BOXER INTEGRATED SEATING - R2**

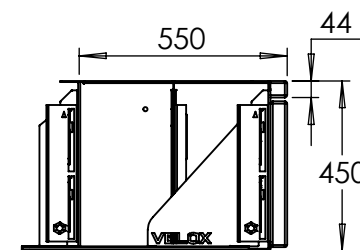
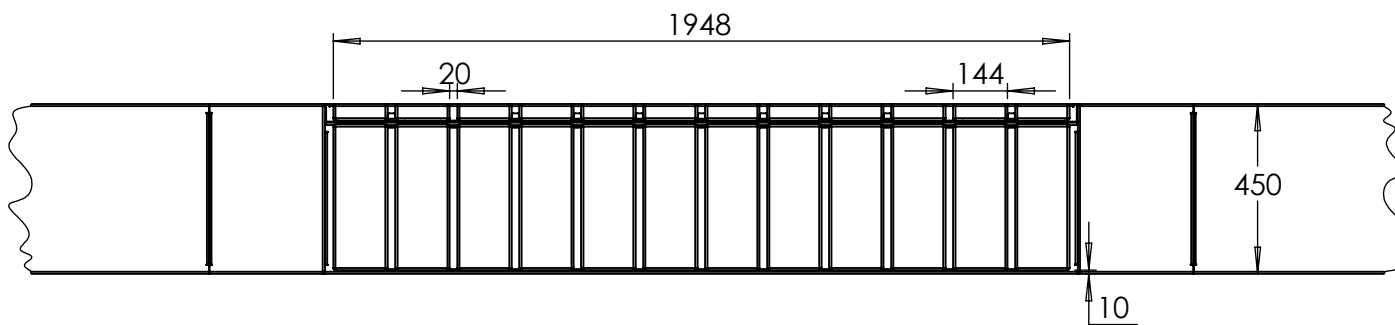
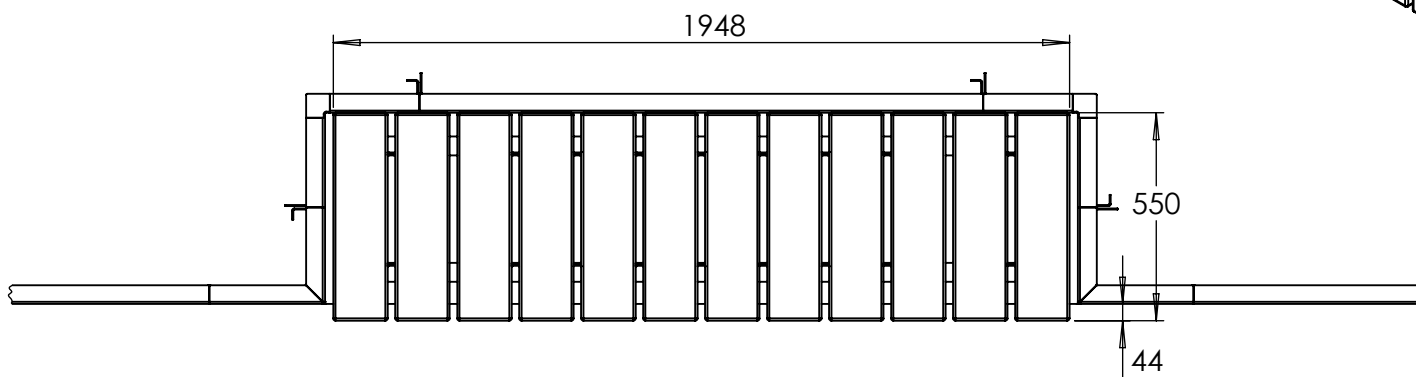
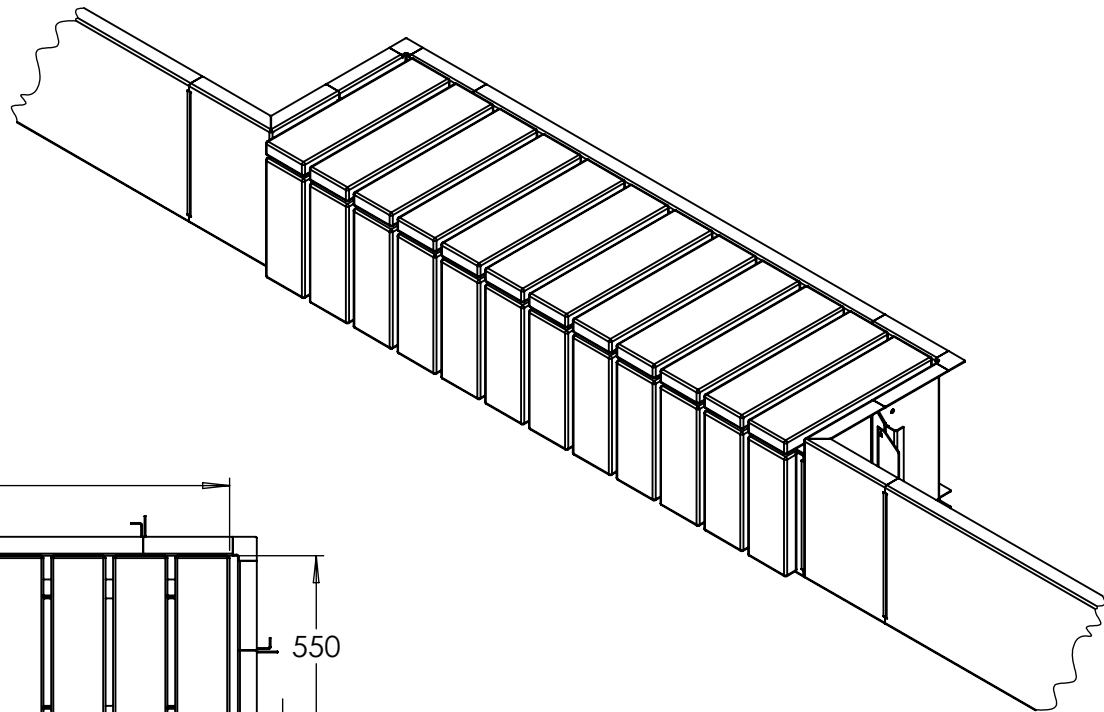

**VELOX Rapid Edge™ UK00003507705 / Patent no: GB2600394 / Registered Design - Europe: 008214910 & UK: 90082149100001** Above FFL mm Below FFL mm Quantity

Agreed Sub-base Material: Lateral Support: Weight

REVISIONS			Drawn By	SA	Linear metre	mm	STAGE	2
REV.	AMENDMENTS/NOTE	DATE	PM	CJ				
P01	INITIAL ISSUE		Timber		144mm x 44mm (Option Dependent)			
			Metal		3mm Steel (Option Dependent)			
			Finish		(Option Dependent)			

**Product**  
Boxer Integrated Bench

**Project:**  
Website Download

**LOGIC™**  
MANUFACTURED BESPOKE

Logic Manufacture Bespoke™  
01642 373400 specification@logic-bespoke.com

DWG. NO. **Boxer Integrated Bench**

Sheet No. **2 of 4** SIZE **A4**

TOLERANCE: All dimensions tolerance +/- 5mm REV. P01



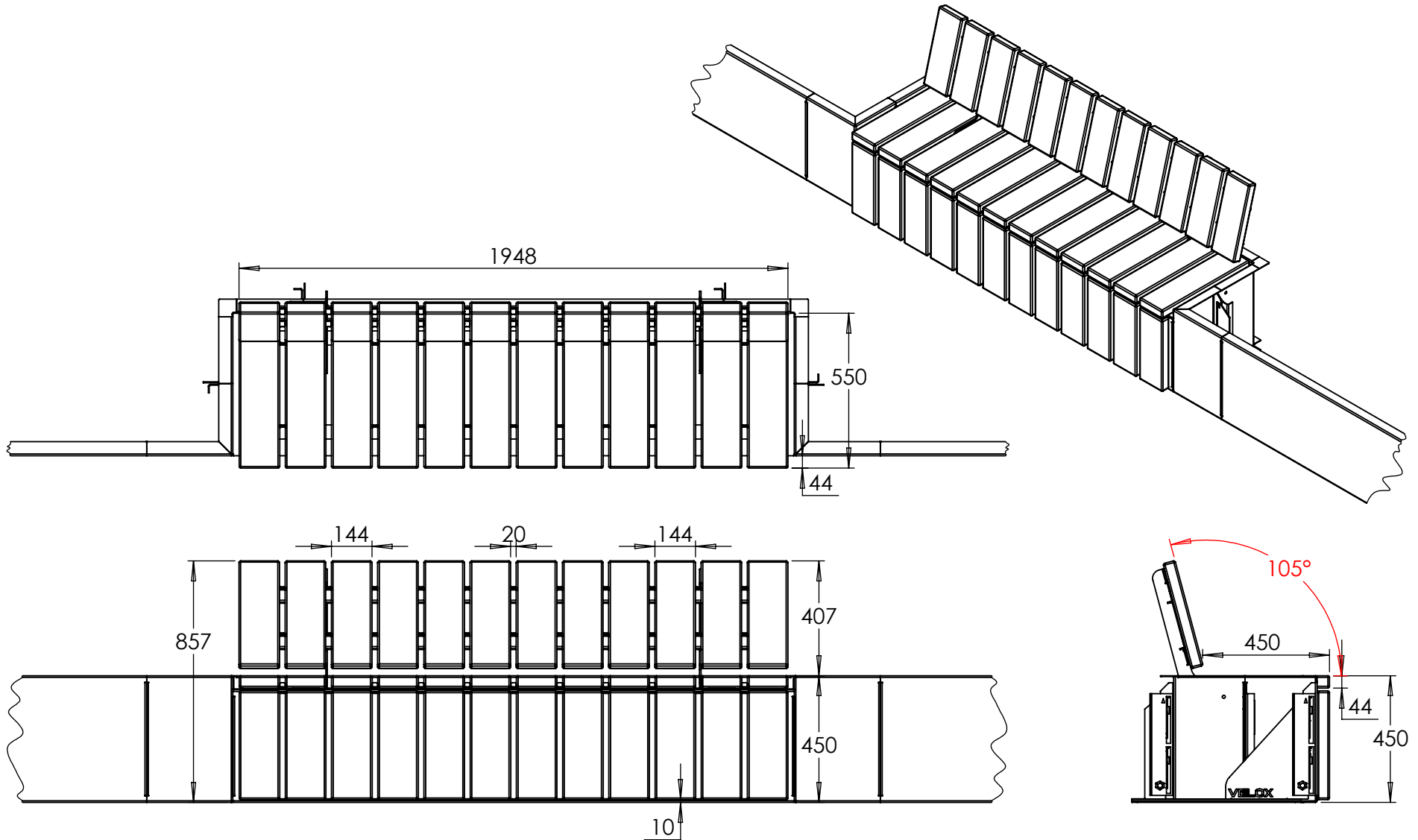

**LOGIC MANUFACTURED BESPOKE™**  
**ALL RIGHTS RESERVED**

Timber Disclaimer: All timbers lose a degree of tanning, some more than others. Timber in an external environment is susceptible to cracking, shelling and moving due to the natural drying process, this does not take away from the durability of the product. In time timber may develop surface discolouration, this is caused by natural mould feeding on the tannins and should disperse as the timber dries and turns silver. Logic are not liable for this natural process and can not be held responsible for any of these natural processes. All products to be installed in conjunction with the supplied installation guide, following the steps & guidance. All Logic products will bear some form of company branding.



**VELOX Rapid Edge™ UK00003507705 / Patent no: GB2600394 / Registered Design - Europe: 008214910 & UK: 90082149100001** Above FFL mm Below FFL mm Quantity

Agreed Sub-base Material: Lateral Support: Weight

REVISIONS			Drawn By	SA	Linear metre	mm	STAGE	2	Product Boxer Integrated Seat	Project: Website Download	 Logic Manufacture Bespoke™ 01642 373400 specification@logic-bespoke.com	Sheet No.	SIZE
REV.	AMENDMENTS/NOTE	DATE	PM	CJ									
P01	INITIAL ISSUE		Timber		144mm x 44mm (Option Dependent)								
			Metal		3mm Steel (Option Dependent)								
			Finish		(Option Dependent)								
TOLERANCE: All dimensions tolerance +/- 5mm			REV. P01	 <b>LOGIC MANUFACTURED BESPOKE™</b> <b>ALL RIGHTS RESERVED</b>		DWG. NO.		<b>Boxer Integrated Bench</b>		Sheet No. 3 of 4	SIZE <b>A4</b>		

Timber Disclaimer: All timbers lose a degree of tanning, some more than others. Timber in an external environment is susceptible to cracking, shelling and moving due to the natural drying process, this does not take away from the durability of the product. In time timber may develop surface discolouration, this is caused by natural mould feeding on the tannins and should disperse as the timber dries and turns silver. Logic are not liable for this natural process and can not be held responsible for any of these natural processes. All products to be installed in conjunction with the supplied installation guide, following the steps & guidance. All Logic products will bear some form of company branding.

Velox Locking Key  
GB2016654.2

Anco Trademark  
UK00004021374

Velox Self Weighted  
GB2614820

Look & Feel / Intellectual Property  
90082149100001

Velox Trademark  
UK00003507705



## **BOXER INTEGRATED SEATING - R2**

Please ensure you consider the following before signing off:

- Dimensions
- Materials / Finishes
- Levels / Elevations
- Sub Base and Finished Floor Level Specification

Contact your Logic Project Manager to proceed.