

TECHNICAL DRAWING PACK

These drawings show all elements of the design and are to signed off prior to production.

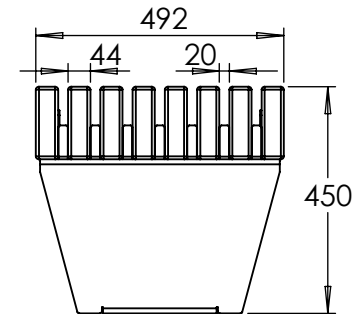
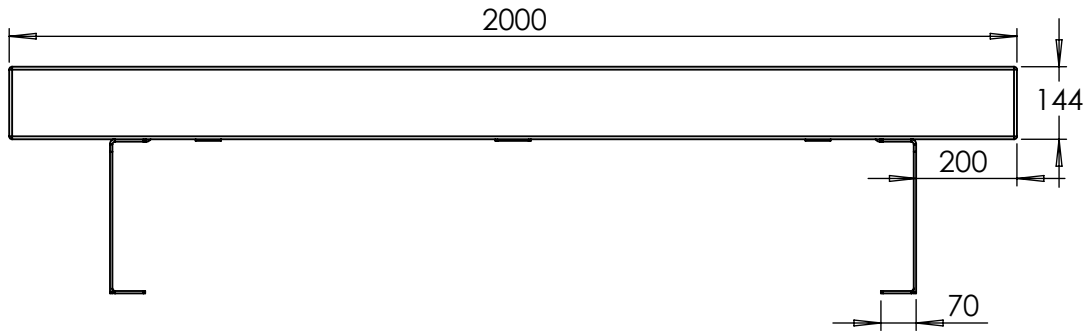
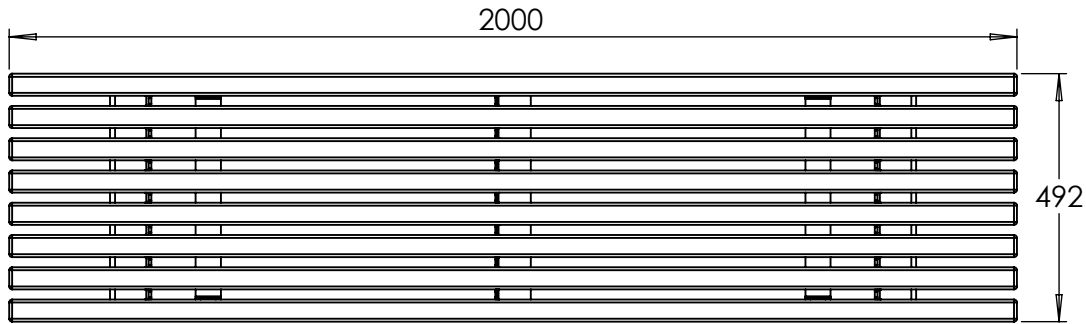
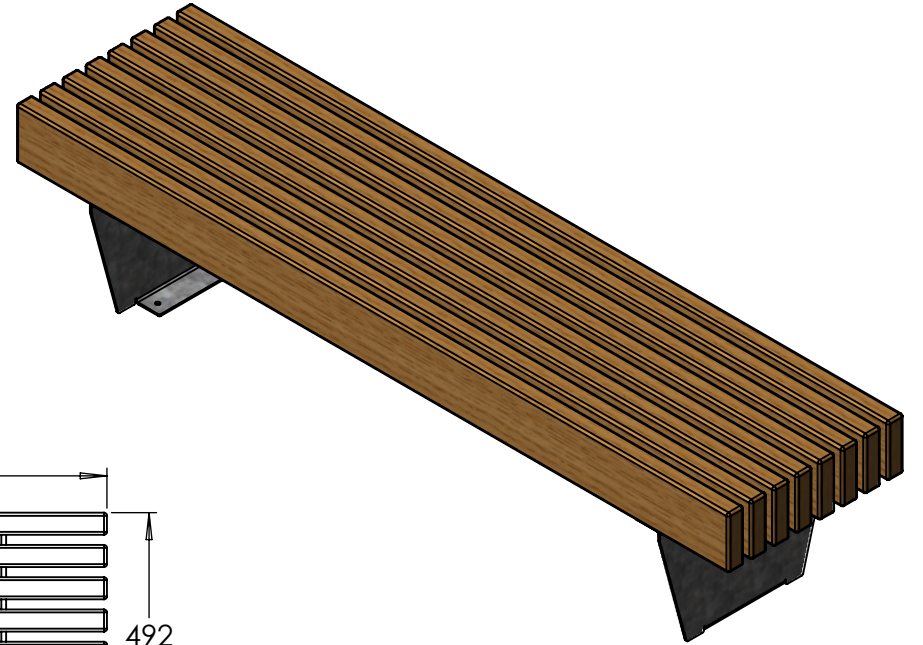

It is important that all details are carefully checked and understood by yourselves as they will be used for manufacture.

ENFUSA BENCH - WEBSITE DOWNLOAD - R2



VELOX Rapid Edge™ UK00003507705 / Patent no: GB2600394 / Registered Design - Europe: 008214910 & UK: 90082149100001 | Above FFL | mm | Below FFL | mm | Quantity | 1

Agreed Sub-base Material: | Lateral Support:

REVISIONS			Drawn By	SA	Linear metre	mm	STAGE	Product ENFUSA BENCH	Project: WEBSITE DOWNLOAD	 Logic Manufacture Bespoke™ 01642 373400 specification@logic-bespoke.com	Sheet No.	SIZE
REV.	AMENDMENTS/NOTE	DATE	PM	CJ								
P02	TIMBER DIMS	11/02/25	Timber		144mm X 44mm (OPTION DEPENDENT)							
			Metal		5mm MILD STEEL - GALVANISED							
			Finish									
TOLERANCE: All dimensions tolerance +/- 5mm			REV. P02	 LOGIC MANUFACTURED BESPOKE™ ALL RIGHTS RESERVED		DWG. NO. Enfusa Bench		2 of 6	A4			

Timber Disclaimer: All timbers lose a degree of tanning, some more than others. Timber in an external environment is susceptible to cracking, shelling and moving due to the natural drying process, this does not take away from the durability of the product. In time timber may develop surface discolouration, this is caused by natural mould feeding on the tannins and should disperse as the timber dries and turns silver. Logic are not liable for this natural process and can not be held responsible for any of these natural processes. All products to be installed in conjunction with the supplied installation guide, following the steps & guidance. All Logic products will bear some form of company branding.

Velox Locking Key
GB2016654.2

Anco Trademark
UK00004021374

Velox Self Weighted
GB2614820

Look & Feel / Intellectual Property
90082149100001

Velox Trademark
UK00003507705



ENFUSA BENCH - WEBSITE DOWNLOAD - R2

Please ensure you consider the following before signing off:

- Dimensions
- Materials / Finishes
- Levels / Elevations
- Sub Base and Finished Floor Level Specification

Contact your Logic Project Manager to proceed.