

VELOX Rapid Edge™ UK00003507705 / Patent no: GB2600394 / Registered Design - Europe: 008214910 & UK: 90082149100001 | Above FFL | 0 mm | Below FFL | 0 mm | Quantity | --

Agreed Sub-base Material: TBC | Lateral Support:

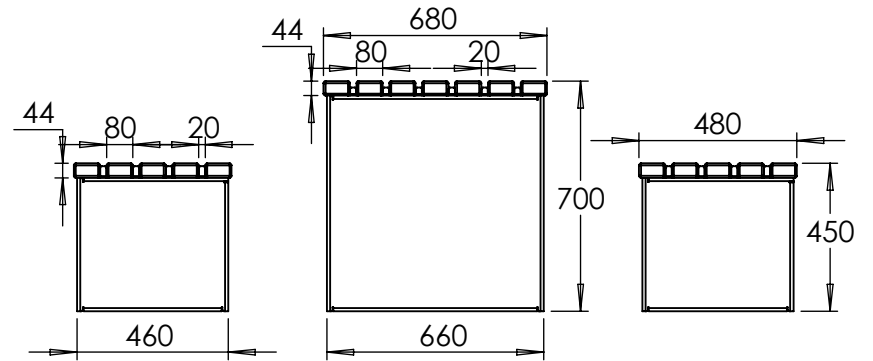
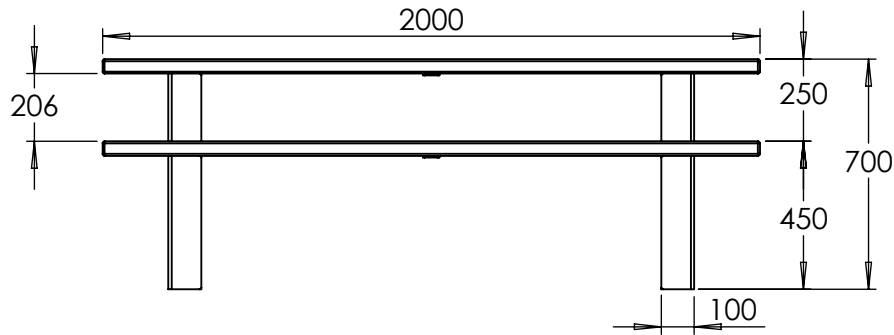
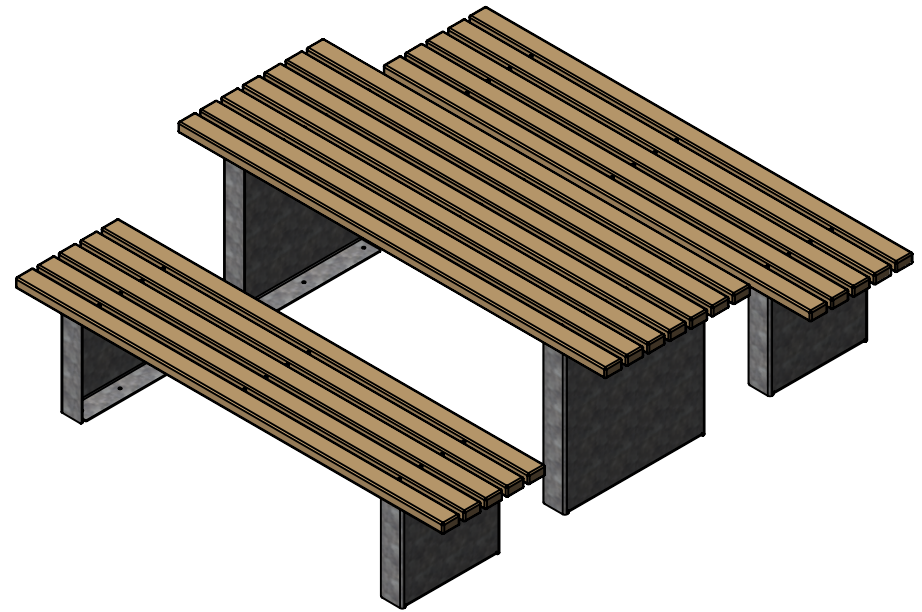
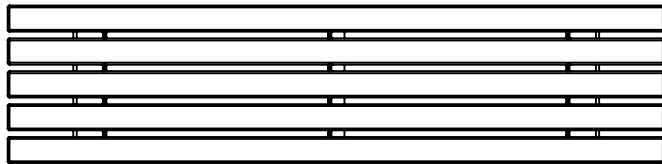
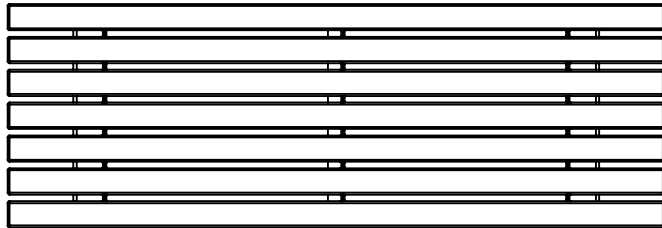
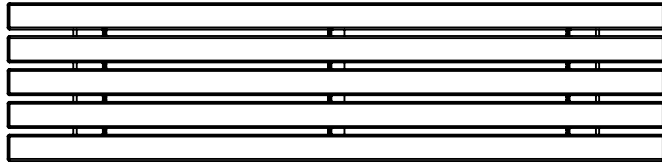

REVISIONS			Drawn By	SA	Linear metre	mm	STAGE	2	Product Modal Table	Project: Website Download	 Logic Manufacture Bespoke™ 01642 373400 specification@logic-bespoke.com	Sheet No.	SIZE
REV.	AMENDMENTS/NOTE	DATE	PM										
P01	INITIAL ISSUE		Timber	Class 1 - Opepe Hardwood									
			Metal	Mild Steel									
			Finish	Galvanised & Powder Coated 7016									
TOLERANCE: All dimensions tolerance +/- 5mm			REV. P01		 LOGIC MANUFACTURED BESPOKE™ ALL RIGHTS RESERVED				DWG. NO.	Modal Table	2 of 4	A4	

Timber Disclaimer: All timbers lose a degree of tanning, some more than others. Timber in an external environment is susceptible to cracking, shelling and moving due to the natural drying process, this does not take away from the durability of the product. In time timber may develop surface discolouration, this is caused by natural mould feeding on the tannins and should disperse as the timber dries and turns silver. Logic are not liable for this natural process and can not be held responsible for any of these natural processes. All products to be installed in conjunction with the supplied installation guide, following the steps & guidance. All Logic products will bear some form of company branding.



VELOX Rapid Edge™ UK00003507705 / Patent no: GB2600394 / Registered Design - Europe: 008214910 & UK: 90082149100001 | Above FFL | 0 mm | Below FFL | 0 mm | Quantity | --

Agreed Sub-base Material: TBC | Lateral Support:

REVISIONS			Drawn By	SA	Linear metre	mm	STAGE	2	Product Modal Table	Project: Website Download	 Logic Manufacture Bespoke™ 01642 373400 specification@logic-bespoke.com	DWG. NO.	Sheet No.	SIZE	
REV.	AMENDMENTS/NOTE	DATE	PM												
P01	INITIAL ISSUE		Timber	Class 1 - Opepe Hardwood											
			Metal	Mild Steel											
			Finish	Galvanised & Powder Coated 7016											
TOLERANCE: All dimensions tolerance +/- 5mm			REV. P01			LOGIC MANUFACTURED BESPOKE™ ALL RIGHTS RESERVED									

Timber Disclaimer: All timbers lose a degree of tanning, some more than others. Timber in an external environment is susceptible to cracking, shelling and moving due to the natural drying process, this does not take away from the durability of the product. In time timber may develop surface discolouration, this is caused by natural mould feeding on the tannins and should disperse as the timber dries and turns silver. Logic are not liable for this natural process and can not be held responsible for any of these natural processes. All products to be installed in conjunction with the supplied installation guide, following the steps & guidance. All Logic products will bear some form of company branding.