

TECHNICAL DRAWING PACK

These drawings show all elements of the design and are to signed off prior to production.

It is important that all details are carefully checked and understood by yourselves as they will be used for manufacture.

MONTE SEATING - REV. P01

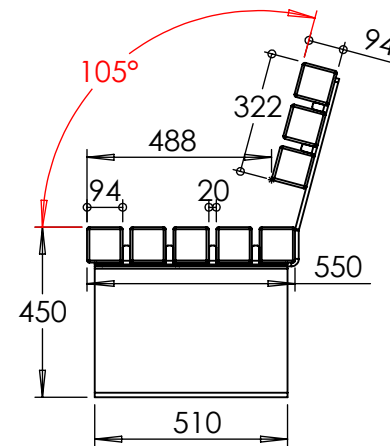
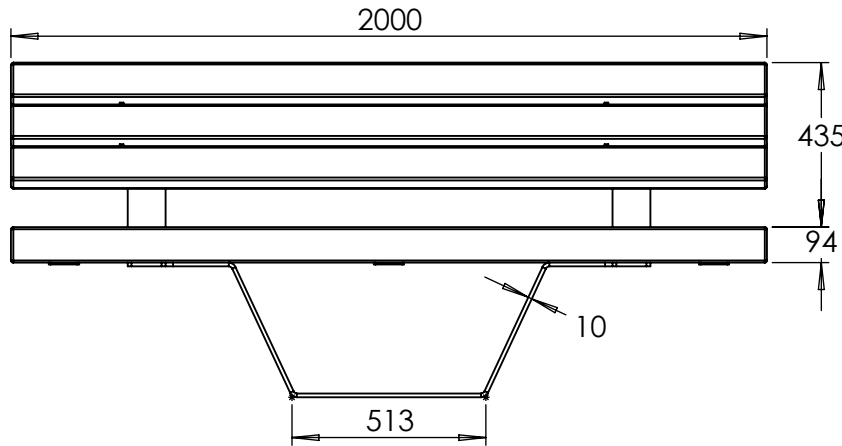
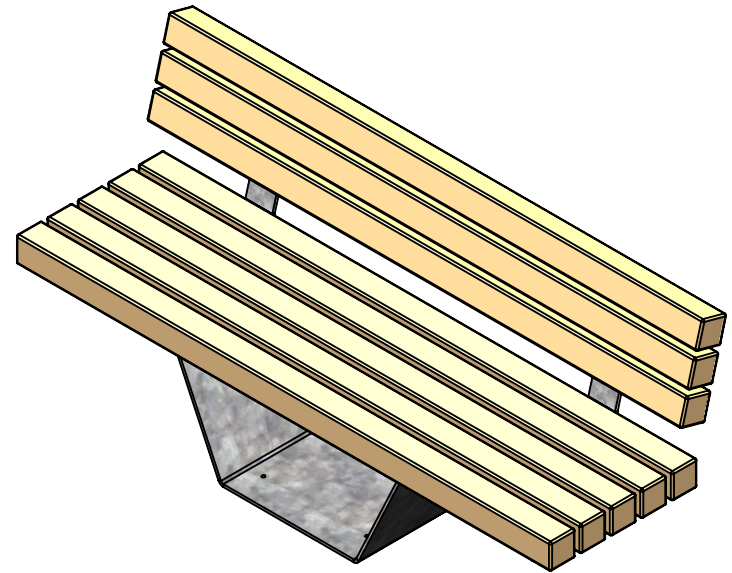
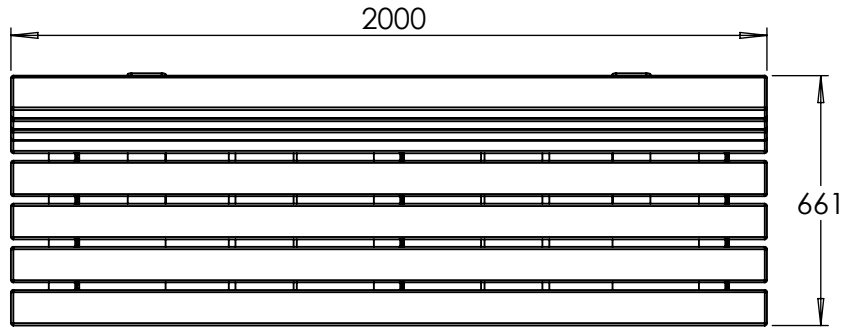

VELOX Rapid Edge™ UK00003507705 / **Patent no:** GB2600394 / **Registered Design - Europe:** 008214910 & **UK:** 90082149100001 | Above FFL | mm | Below FFL | mm | Quantity |

Agreed Sub-base Material: | Lateral Support: | Weight | 187.1 kg

REVISIONS		
REV.	AMENDMENTS/NOTE	DATE
P01	TIMBER CHANGE	27/02/25

Drawn By	SA	Linear metre	mm	STAGE	2
PM	CJ				
Timber	94mm x 94mm (Option Dependent)				
Metal	10mm Steel (Option Dependent)				
Finish	Option Dependent				

Product
Monte Seat

Project:
Website Download

LOGIC™
MANUFACTURED BESPOKE

Logic Manufacture Bespoke™
01642 373400 specification@logic-bespoke.com

DWG. NO. | Sheet No. | SIZE

Monte Seating | 2 of 6 | A4

TOLERANCE: All dimensions tolerance +/- 5mm | REV. P01



LOGIC MANUFACTURED BESPOKE™
ALL RIGHTS RESERVED

Timber Disclaimer: All timbers lose a degree of tanning, some more than others. Timber in an external environment is susceptible to cracking, shelling and moving due to the natural drying process, this does not take away from the durability of the product. In time timber may develop surface discolouration, this is caused by natural mould feeding on the tannins and should disperse as the timber dries and turns silver. Logic are not liable for this natural process and can not be held responsible for any of these natural processes. All products to be installed in conjunction with the supplied installation guide, following the steps & guidance. All Logic products will bear some form of company branding.

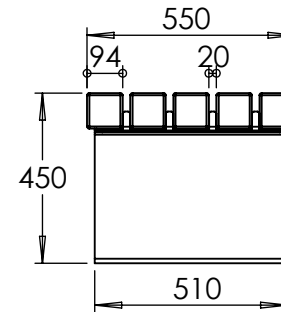
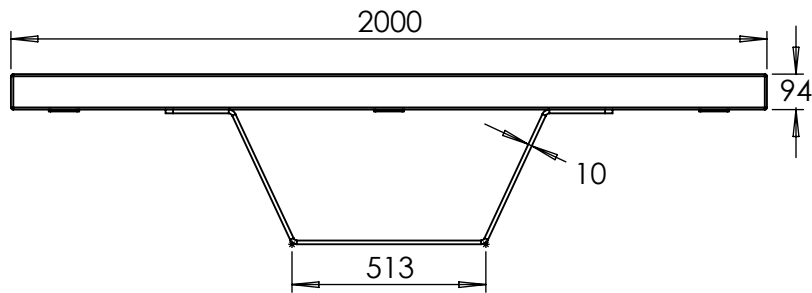
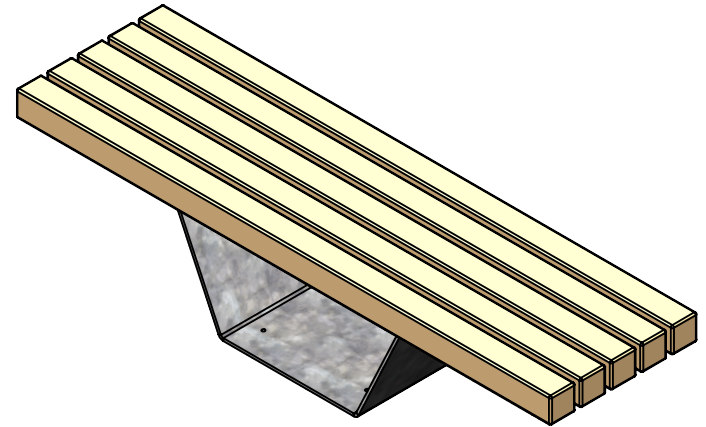
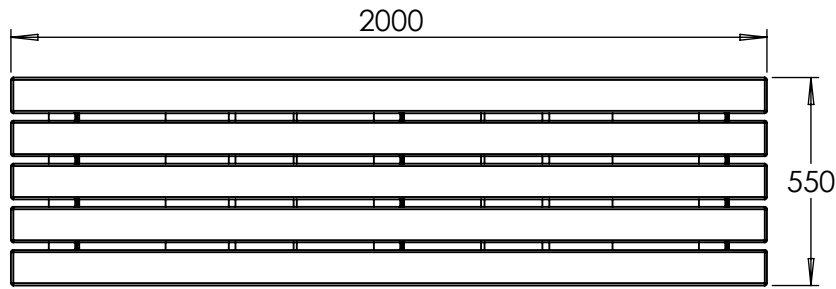

VELOX Rapid Edge™ UK00003507705 / Patent no: GB2600394 / Registered Design - Europe: 008214910 & UK: 90082149100001				Above FFL	mm	Below FFL	mm	Quantity	
Agreed Sub-base Material:						Lateral Support:		Weight	130.9 kg

REVISIONS		
REV.	AMENDMENTS/NOTE	DATE
P01	TIMBER CHANGE	27/02/25

Drawn By	SA	Linear metre	mm	STAGE	2
PM	CJ				
Timber	94mm x 94mm (Option Dependent)				
Metal	10mm Steel (Option Dependent)				
Finish	Option Dependent				
LOGIC MANUFACTURED BESPOKE™ ALL RIGHTS RESERVED					

Product Monte Bench
Project: Website Download



Logic Manufacture Bespoke™
01642 373400 specification@logic-bespoke.com

DWG. NO. Monte Seating	Sheet No. 4 of 6	SIZE A4
---------------------------	---------------------	------------

Timber Disclaimer: All timbers lose a degree of tanning, some more than others. Timber in an external environment is susceptible to cracking, shelling and moving due to the natural drying process, this does not take away from the durability of the product. In time timber may develop surface discolouration, this is caused by natural mould feeding on the tannins and should disperse as the timber dries and turns silver. Logic are not liable for this natural process and can not be held responsible for any of these natural processes. All products to be installed in conjunction with the supplied installation guide, following the steps & guidance. All Logic products will bear some form of company branding.

Velox Locking Key
GB2016654.2

Anco Trademark
UK00004021374

Velox Self Weighted
GB2614820

Look & Feel / Intellectual Property
90082149100001

Velox Trademark
UK00003507705



MONTE SEATING - REV. P01

Please ensure you consider the following before signing off:

- Dimensions
- Materials / Finishes
- Levels / Elevations
- Sub Base and Finished Floor Level Specification

Contact your Logic Project Manager to proceed.