

| | | | | | | | | | | | | |
|--|-----------------|------|----------|--|------------------|---|-----------|----------|--|------|--|--|
| VELOX Rapid Edge™ UK00003507705 / Patent no: GB2600394 / Registered Design - Europe: 008214910 & UK: 90082149100001 | | | | | Above FFL | mm | Below FFL | mm | Quantity | 1 | | |
| Agreed Sub-base Material: | | | | | Lateral Support: | | | Weight | | | | |
| REVISIONS | | | Drawn By | SA | Linear metre | mm | STAGE | 2 | Product PLATEU SEAT INC ARMS Project: WEBSITE DRAWING | | | |
| REV. | AMENDMENTS/NOTE | DATE | PM | CJ | | | | | | | | |
| P01 | INITIAL ISSUE | | Timber | 94mm X 94mm | | | | | | | | |
| | | | Metal | OPTION DEPENDENT | | | | | | | | |
| | | | Finish | | | | | | | | | |
| TOLERANCE: All dimensions tolerance +/- 5mm | | | REV. P01 | LOGIC MANUFACTURED BESPOKE™ ALL RIGHTS RESERVED | | Logic Manufacture Bespoke™ 01642 373400 specification@logic-bespoke.com | | DWG. NO. | Sheet No. | SIZE | | |
| | | | | | XXXX-BXX | | 1 of 8 | | A4 | | | |

Timber Disclaimer: All timbers lose a degree of tanning, some more than others. Timber in an external environment is susceptible to cracking, shelling and moving due to the natural drying process, this does not take away from the durability of the product. In time timber may develop surface discolouration, this is caused by natural mould feeding on the tannins and should disperse as the timber dries and turns silver. Logic are not liable for this natural process and can not be held responsible for any of these natural processes. All products to be installed in conjunction with the supplied installation guide, following the steps & guidance. All Logic products will bear some form of company branding.

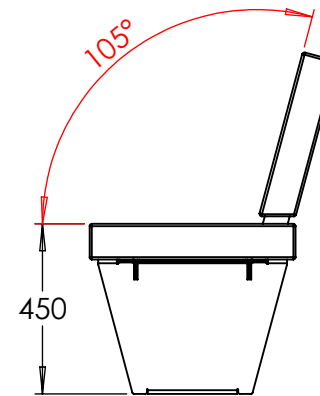

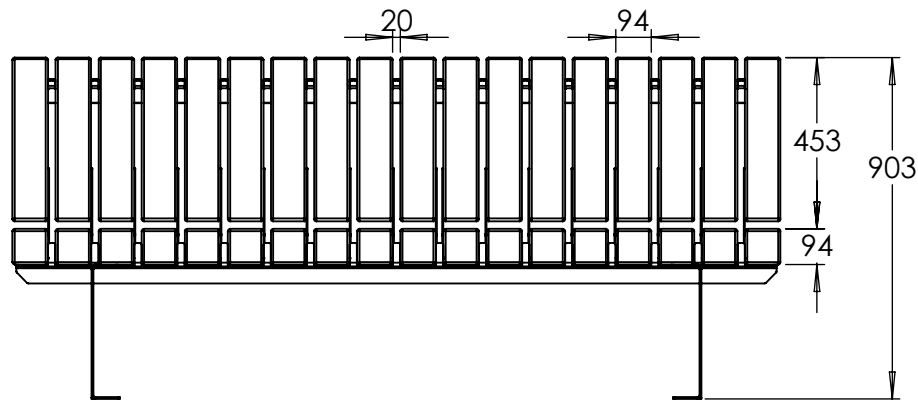
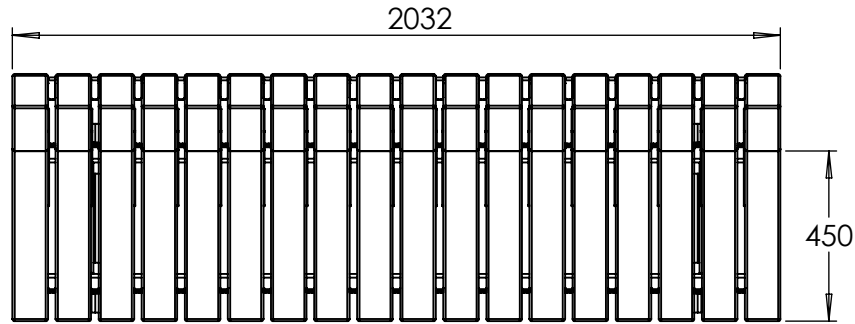

| | | | | | | | | | | | | |
|--|-----------------|------|----------|--|------------------|---|-----------|----------|---|------|--|--|
| VELOX Rapid Edge™ UK00003507705 / Patent no: GB2600394 / Registered Design - Europe: 008214910 & UK: 90082149100001 | | | | | Above FFL | mm | Below FFL | mm | Quantity | 1 | | |
| Agreed Sub-base Material: | | | | | Lateral Support: | | | Weight | | | | |
| REVISIONS | | | Drawn By | SA | Linear metre | mm | STAGE | 2 | Product PLATEU SEAT NO ARMS Project: WEBSITE DRAWING | | | |
| REV. | AMENDMENTS/NOTE | DATE | PM | CJ | | | | | | | | |
| P01 | INITIAL ISSUE | | Timber | 94mm X 94mm | | | | | | | | |
| | | | Metal | OPTION DEPENDENT | | | | | | | | |
| | | | Finish | | | | | | | | | |
| TOLERANCE: All dimensions tolerance +/- 5mm | | | REV. P01 | LOGIC MANUFACTURED BESPOKE™ ALL RIGHTS RESERVED | | Logic Manufacture Bespoke™ 01642 373400 specification@logic-bespoke.com | | DWG. NO. | Sheet No. | SIZE | | |
| | | | | | XXXX-BXX | | 2 of 8 | | A4 | | | |

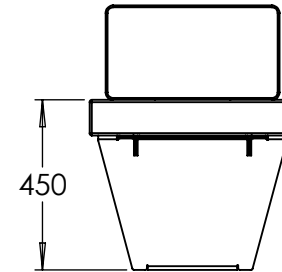
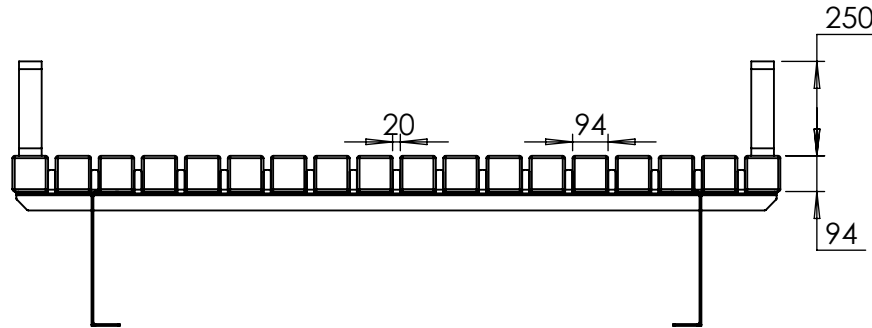
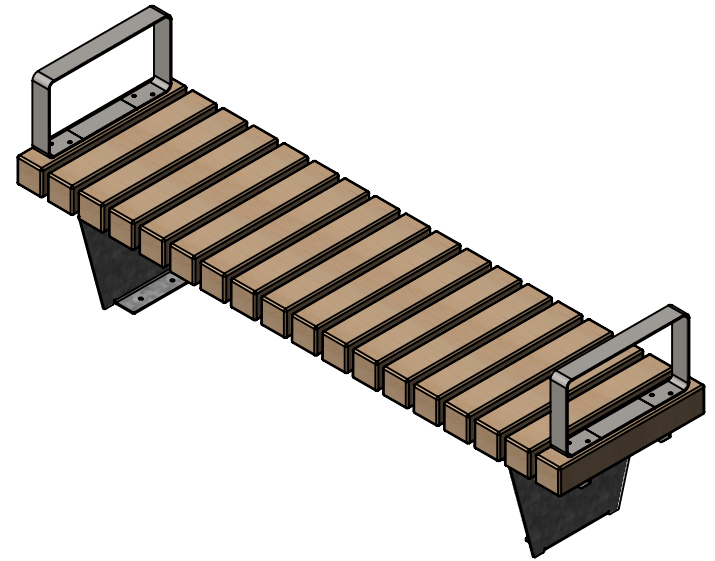
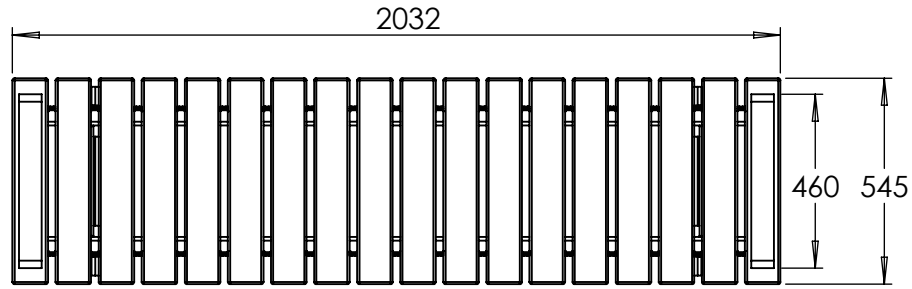
Timber Disclaimer: All timbers lose a degree of tanning, some more than others. Timber in an external environment is susceptible to cracking, shelling and moving due to the natural drying process, this does not take away from the durability of the product. In time timber may develop surface discolouration, this is caused by natural mould feeding on the tannins and should disperse as the timber dries and turns silver. Logic are not liable for this natural process and can not be held responsible for any of these natural processes. All products to be installed in conjunction with the supplied installation guide, following the steps & guidance. All Logic products will bear some form of company branding.



VELOX Rapid Edge™ UK00003507705 / **Patent no:** GB2600394 / **Registered Design - Europe:** 008214910 & **UK:** 90082149100001 | Above FFL | mm | Below FFL | mm | Quantity | 1

Agreed Sub-base Material: | Lateral Support: | Weight

| REVISIONS | | | Drawn By | SA | Linear metre | mm | STAGE | 2 | Product PLATEU BENCH INC ARMS | Project: WEBSITE DRAWING |  Logic Manufacture Bespoke™ 01642 373400 specification@logic-bespoke.com | Sheet No. | SIZE |
|---|-----------------|------|----------|----|--|----|-------|---|----------------------------------|-----------------------------|---|-----------|----------|
| REV. | AMENDMENTS/NOTE | DATE | PM | CJ | | | | | | | | DWG. NO. | XXXX-BXX |
| P01 | INITIAL ISSUE | | Timber | | 94mm X 94mm | | | | | | | | |
| | | | Metal | | OPTION DEPENDENT | | | | | | | | |
| | | | Finish | | | | | | | | | | |
| TOLERANCE: All dimensions tolerance +/- 5mm | | | REV. P01 | |  LOGIC MANUFACTURED BESPOKE™ ALL RIGHTS RESERVED | | | | | | | | |

Timber Disclaimer: All timbers lose a degree of tanning, some more than others. Timber in an external environment is susceptible to cracking, shelling and moving due to the natural drying process, this does not take away from the durability of the product. In time timber may develop surface discolouration, this is caused by natural mould feeding on the tannins and should disperse as the timber dries and turns silver. Logic are not liable for this natural process and can not be held responsible for any of these natural processes. All products to be installed in conjunction with the supplied installation guide, following the steps & guidance. All Logic products will bear some form of company branding.

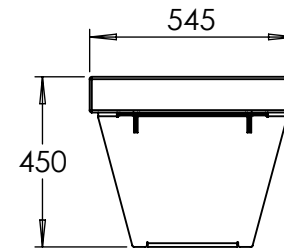
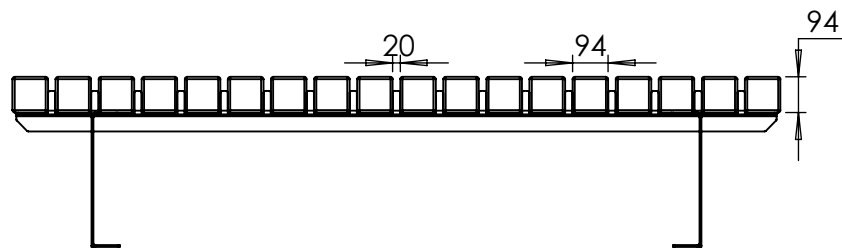
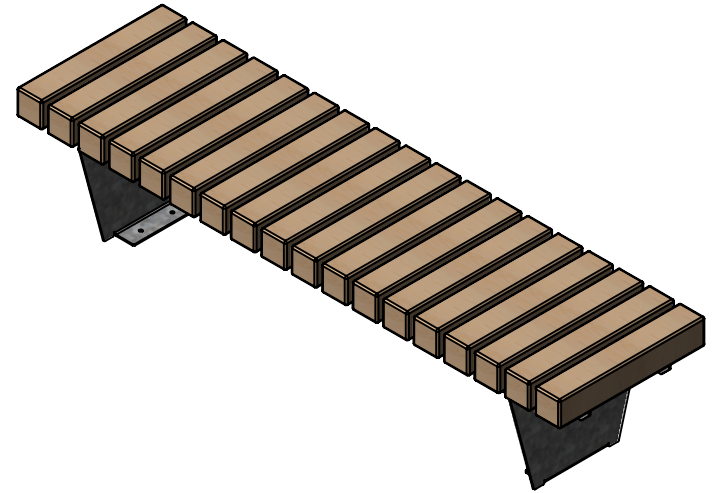
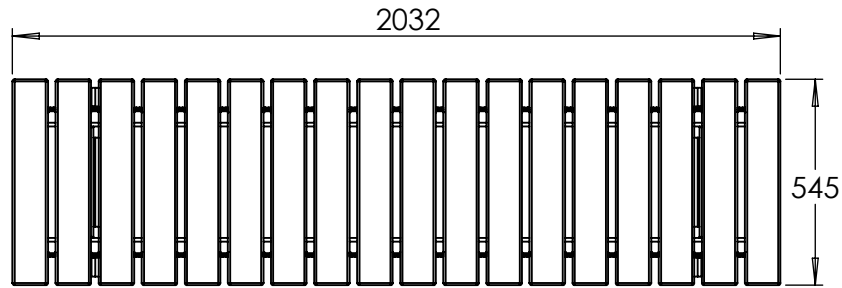

| | | | | | | | | | | | | |
|--|-----------------|------|----------|--|------------------|---|-----------|----------|--|------|--|--|
| VELOX Rapid Edge™ UK00003507705 / Patent no: GB2600394 / Registered Design - Europe: 008214910 & UK: 90082149100001 | | | | | Above FFL | mm | Below FFL | mm | Quantity | 1 | | |
| Agreed Sub-base Material: | | | | | Lateral Support: | | | Weight | | | | |
| REVISIONS | | | Drawn By | SA | Linear metre | mm | STAGE | 2 | Product PLATEU BENCH NO ARMS Project: WEBSITE DRAWING | | | |
| REV. | AMENDMENTS/NOTE | DATE | PM | CJ | | | | | | | | |
| P01 | INITIAL ISSUE | | Timber | 94mm X 94mm | | | | | | | | |
| | | | Metal | OPTION DEPENDENT | | | | | | | | |
| | | | Finish | | | | | | | | | |
| TOLERANCE: All dimensions tolerance +/- 5mm | | | REV. P01 | LOGIC MANUFACTURED BESPOKE™ ALL RIGHTS RESERVED | | Logic Manufacture Bespoke™ 01642 373400 specification@logic-bespoke.com | | DWG. NO. | Sheet No. | SIZE | | |
| | | | | | | XXXX-BXX | | 4 of 8 | A4 | | | |

Timber Disclaimer: All timbers lose a degree of tanning, some more than others. Timber in an external environment is susceptible to cracking, shelling and moving due to the natural drying process, this does not take away from the durability of the product. In time timber may develop surface discolouration, this is caused by natural mould feeding on the tannins and should disperse as the timber dries and turns silver. Logic are not liable for this natural process and can not be held responsible for any of these natural processes. All products to be installed in conjunction with the supplied installation guide, following the steps & guidance. All Logic products will bear some form of company branding.

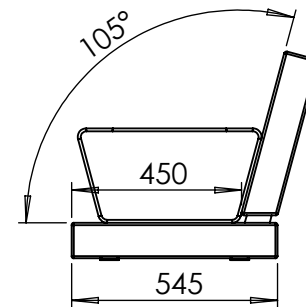
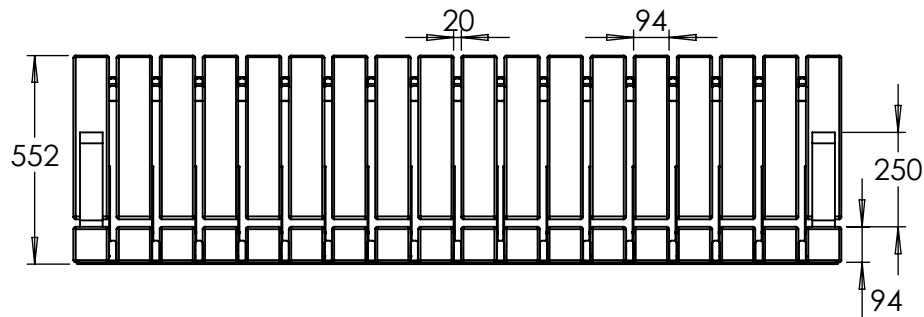
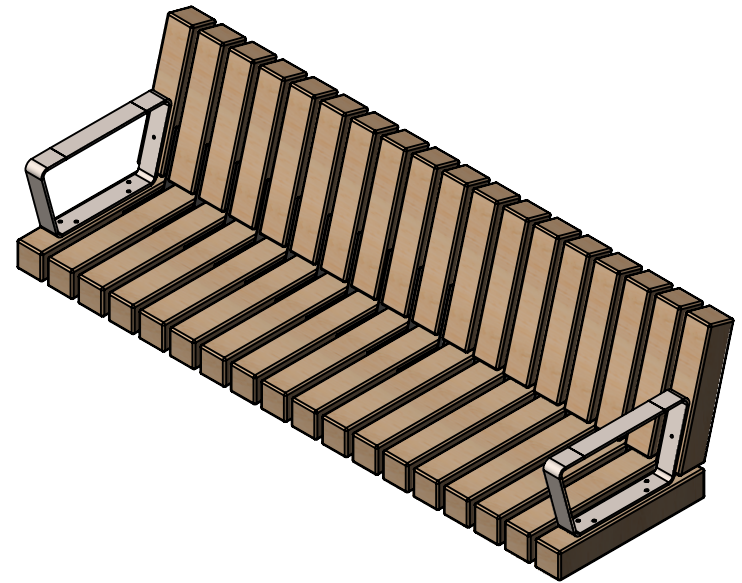
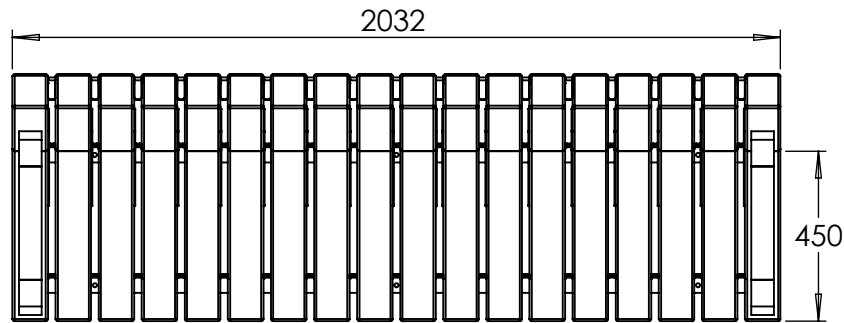

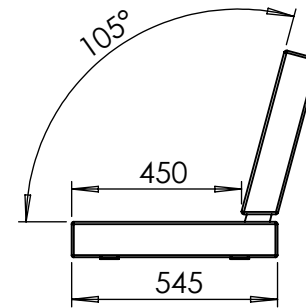
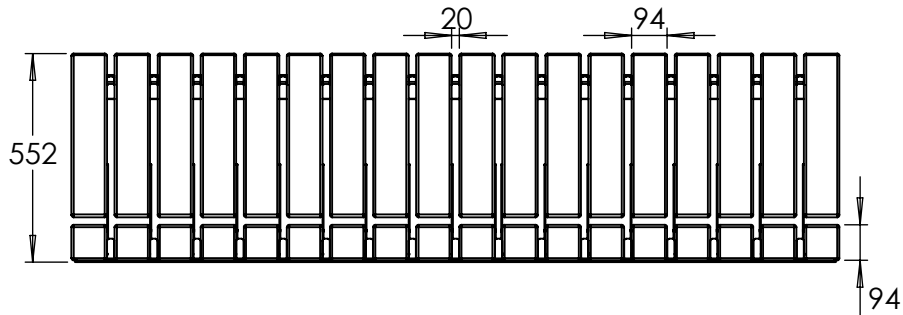
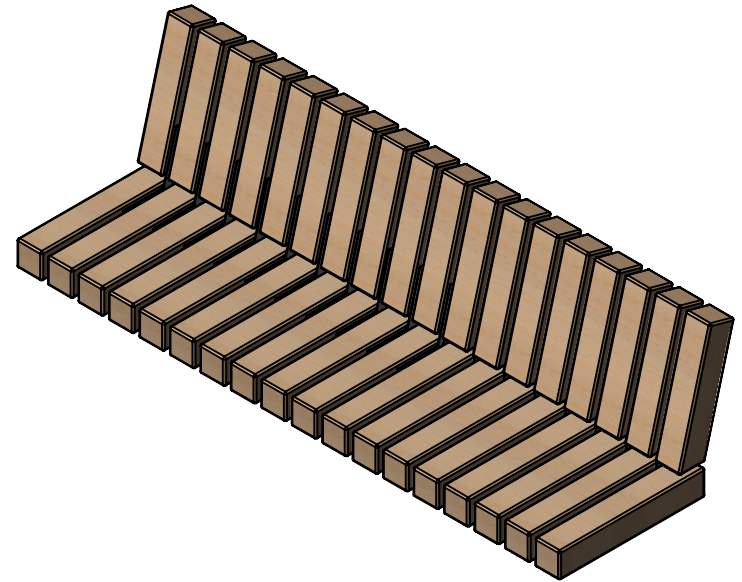
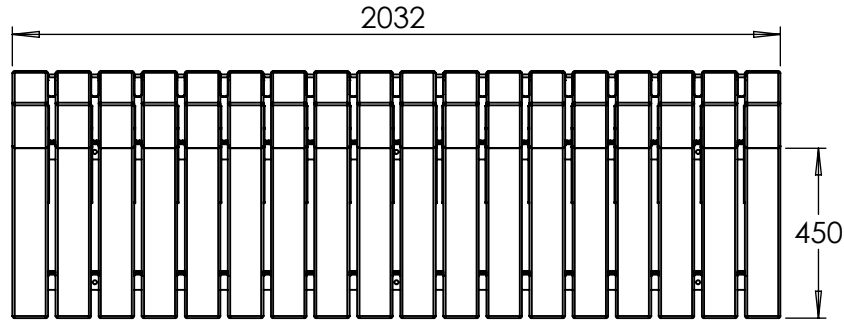

| | | | | | | | | | | |
|--|-----------------|------|----------|--|--------------|---|-------|-----------------------------|---|-------------------|
| VELOX Rapid Edge™ UK00003507705 / Patent no: GB2600394 / Registered Design - Europe: 008214910 & UK: 90082149100001 | | | | Above FFL | mm | Below FFL | mm | Quantity | 1 | |
| Agreed Sub-base Material: | | | | | | Lateral Support: | | Weight | | |
| REVISIONS | | | Drawn By | SA | Linear metre | mm | STAGE | 2 | Product PLATEU WALL SEAT INC ARMS Project: WEBSITE DRAWING | |
| REV. | AMENDMENTS/NOTE | DATE | PM | CJ | | | | | | |
| P01 | INITIAL ISSUE | | Timber | 94mm X 94mm | | | | | | |
| | | | Metal | OPTION DEPENDENT | | | | | | |
| | | | Finish | | | | | | | |
| TOLERANCE: All dimensions tolerance +/- 5mm | | | REV. P01 | LOGIC MANUFACTURED BESPOKE™ ALL RIGHTS RESERVED | | Logic Manufacture Bespoke™ 01642 373400 specification@logic-bespoke.com | | DWG. NO. XXXX-BXX | Sheet No. 5 of 8 | SIZE A4 |

Timber Disclaimer: All timbers lose a degree of tanning, some more than others. Timber in an external environment is susceptible to cracking, shelling and moving due to the natural drying process, this does not take away from the durability of the product. In time timber may develop surface discolouration, this is caused by natural mould feeding on the tannins and should disperse as the timber dries and turns silver. Logic are not liable for this natural process and can not be held responsible for any of these natural processes. All products to be installed in conjunction with the supplied installation guide, following the steps & guidance. All Logic products will bear some form of company branding.



VELOX Rapid Edge™ UK00003507705 / **Patent no:** GB2600394 / **Registered Design - Europe:** 008214910 & **UK:** 90082149100001 | Above FFL | mm | Below FFL | mm | Quantity | 1

Agreed Sub-base Material: | Lateral Support: | Weight

| REVISIONS | | | Drawn By | SA | Linear metre | mm | STAGE | 2 | Product PLATEU WALL SEAT NO ARMS | Project: WEBSITE DRAWING |  Logic Manufacture Bespoke™ 01642 373400 specification@logic-bespoke.com | Sheet No. | SIZE |
|---|-----------------|------|----------|----|--|----|-----------------------------|---|-------------------------------------|-----------------------------|---|-----------|------|
| REV. | AMENDMENTS/NOTE | DATE | PM | CJ | | | | | | | | | |
| P01 | INITIAL ISSUE | | Timber | | 94mm X 94mm | | | | | | | | |
| | | | Metal | | OPTION DEPENDENT | | | | | | | | |
| | | | Finish | | | | | | | | | | |
| TOLERANCE: All dimensions tolerance +/- 5mm | | | REV. P01 | |  LOGIC MANUFACTURED BESPOKE™ ALL RIGHTS RESERVED | | DWG. NO. XXXX-BXX | | Sheet No. 6 of 8 | | SIZE A4 | | |

Timber Disclaimer: All timbers lose a degree of tanning, some more than others. Timber in an external environment is susceptible to cracking, shelling and moving due to the natural drying process, this does not take away from the durability of the product. In time timber may develop surface discolouration, this is caused by natural mould feeding on the tannins and should disperse as the timber dries and turns silver. Logic are not liable for this natural process and can not be held responsible for any of these natural processes. All products to be installed in conjunction with the supplied installation guide, following the steps & guidance. All Logic products will bear some form of company branding.

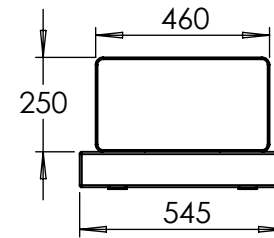
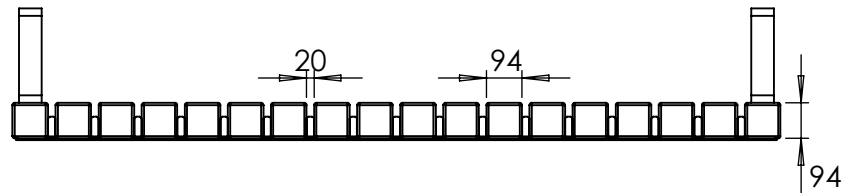
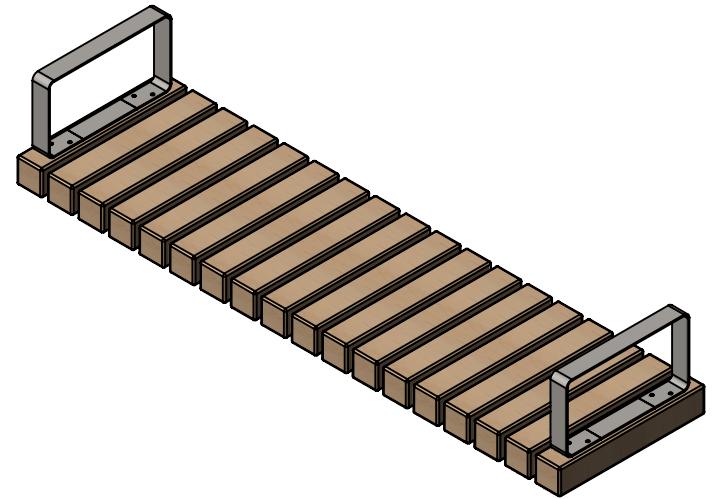
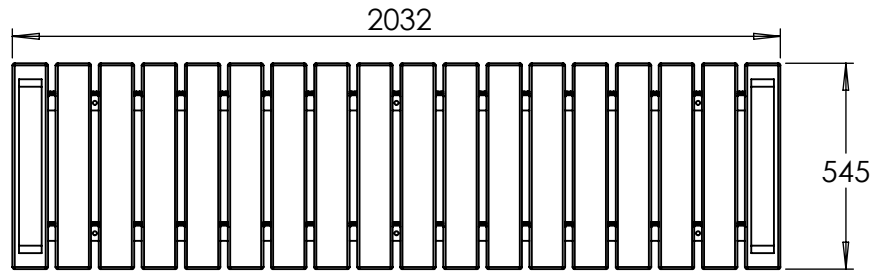

| | | | | | | | | | | |
|--|-----------------|--|----------|-----------------------|------------------|--|-----------|--|------------------------------------|------|
| VELOX Rapid Edge™ UK00003507705 / Patent no: GB2600394 / Registered Design - Europe: 008214910 & UK: 90082149100001 | | | | | Above FFL | mm | Below FFL | mm | Quantity | 1 |
| Agreed Sub-base Material: | | | | | Lateral Support: | | | Weight | | |
| REVISIONS | | | Drawn By | SA | Linear metre | mm | STAGE | 2 | Product | |
| REV. | AMENDMENTS/NOTE | | DATE | PM | CJ | | | | PLATEU WALL BENCH INC ARMS | |
| P01 | INITIAL ISSUE | | | Timber | 94mm X 94mm | | | | Project: WEBSITE DRAWING | |
| | | | | Metal | OPTION DEPENDENT | | | | | |
| | | | | Finish | | | | | | |
| TOLERANCE: All dimensions tolerance +/- 5mm | | | REV. P01 | DO NOT SCALE DRAWINGS | | LOGIC MANUFACTURED BESPOKE™ ALL RIGHTS RESERVED | | Logic Manufacture Bespoke™ 01642 373400 specification@logic-bespoke.com | | |
| | | | | | | | | DWG. NO. | Sheet No. | SIZE |
| | | | | | | | | XXXX-BXX | 7 of 8 | A4 |

Timber Disclaimer: All timbers lose a degree of tanning, some more than others. Timber in an external environment is susceptible to cracking, shelling and moving due to the natural drying process, this does not take away from the durability of the product. In time timber may develop surface discolouration, this is caused by natural mould feeding on the tannins and should disperse as the timber dries and turns silver. Logic are not liable for this natural process and can not be held responsible for any of these natural processes. All products to be installed in conjunction with the supplied installation guide, following the steps & guidance. All Logic products will bear some form of company branding.

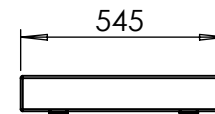
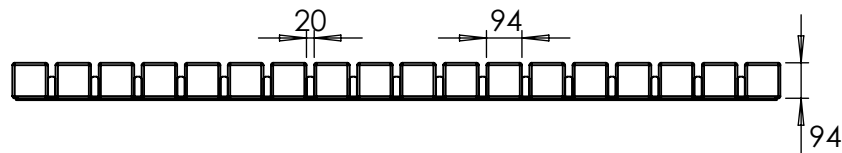
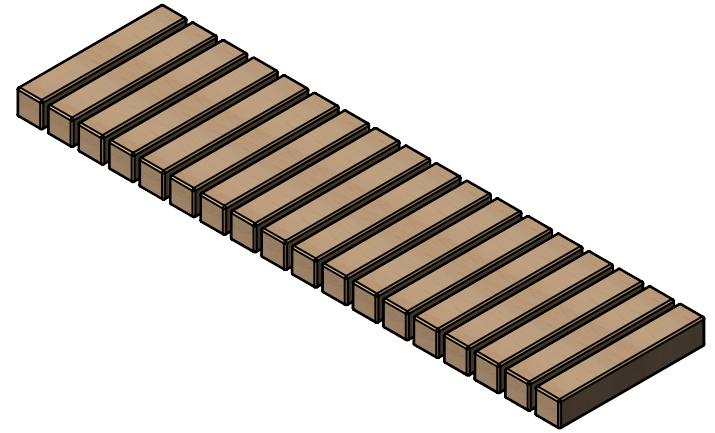
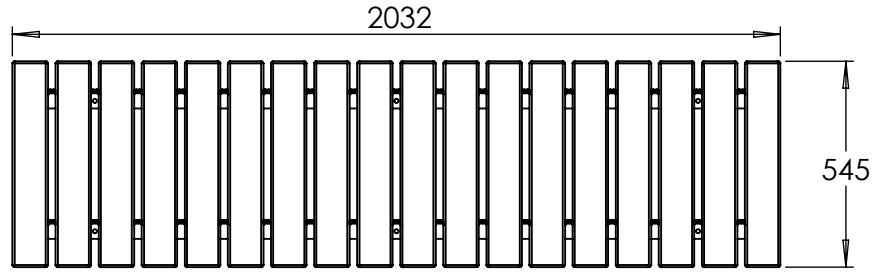

| | | | | | | | | | |
|--|-----------------|------|----------|--|--------------|--|--------|----------|---|
| VELOX Rapid Edge™ UK00003507705 / Patent no: GB2600394 / Registered Design - Europe: 008214910 & UK: 90082149100001 | | | | Above FFL | mm | Below FFL | mm | Quantity | 1 |
| Agreed Sub-base Material: | | | | | | Lateral Support: | | Weight | |
| REVISIONS | | | Drawn By | SA | Linear metre | mm | STAGE | 2 | Product PLATEU WALL BENCH NO ARMS Project: WEBSITE DRAWING |
| REV. | AMENDMENTS/NOTE | DATE | PM | CJ | | | | | |
| P01 | INITIAL ISSUE | | Timber | 94mm X 94mm | | | | | |
| | | | Metal | OPTION DEPENDENT | | | | | |
| | | | Finish | | | | | | |
| TOLERANCE: All dimensions tolerance +/- 5mm | | | REV. P01 | LOGIC MANUFACTURED BESPOKE™ ALL RIGHTS RESERVED | | Logic Manufacture Bespoke™ 01642 373400 specification@logic-bespoke.com | | DWG. NO. | Sheet No. |
| | | | | | XXXX-BXX | | 8 of 8 | SIZE | A4 |

Timber Disclaimer: All timbers lose a degree of tanning, some more than others. Timber in an external environment is susceptible to cracking, shelling and moving due to the natural drying process, this does not take away from the durability of the product. In time timber may develop surface discolouration, this is caused by natural mould feeding on the tannins and should disperse as the timber dries and turns silver. Logic are not liable for this natural process and can not be held responsible for any of these natural processes. All products to be installed in conjunction with the supplied installation guide, following the steps & guidance. All Logic products will bear some form of company branding.