

VELOX Rapid Edge™ UK00003507705 / Patent no: GB2600394 / Registered Design - Europe: 008214910 & UK: 90082149100001		Above FFL	mm	Below FFL	mm	Quantity	-
---	--	-----------	----	-----------	----	----------	---

Agreed Sub-base Material:				Lateral Support:			
---------------------------	--	--	--	------------------	--	--	--

REVISIONS			Drawn By	SA	Linear metre	mm	STAGE	Product PLATEAU BENCH	Project:	
REV.	AMENDMENTS/NOTE	DATE	PM							
P01	INITIAL ISSUE		Timber		2000X94X94	OPTION DEPENDENT				Logic Manufacture Bespoke™ 01642 373400 specification@logic-bespoke.com
			Metal		5mm	OPTION DEPENDENT				DWG. NO. XXXX-BXX
			Finish							Sheet No. 9 of 14
TOLERANCE: All dimensions tolerance +/- 5mm			REV. P01		LOGIC MANUFACTURED BESPOKE™ ALL RIGHTS RESERVED					SIZE A4

Timber Disclaimer: All timbers lose a degree of tanning, some more than others. Timber in an external environment is susceptible to cracking, shelling and moving due to the natural drying process, this does not take away from the durability of the product. In time timber may develop surface discolouration, this is caused by natural mould feeding on the tannins and should disperse as the timber dries and turns silver. Logic are not liable for this natural process and can not be held responsible for any of these natural processes. All products to be installed in conjunction with the supplied installation guide, following the steps & guidance. All Logic products will bear some form of company branding.

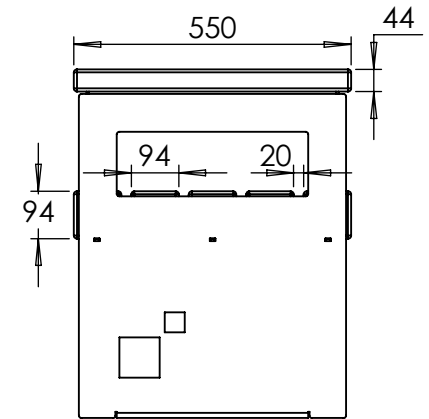
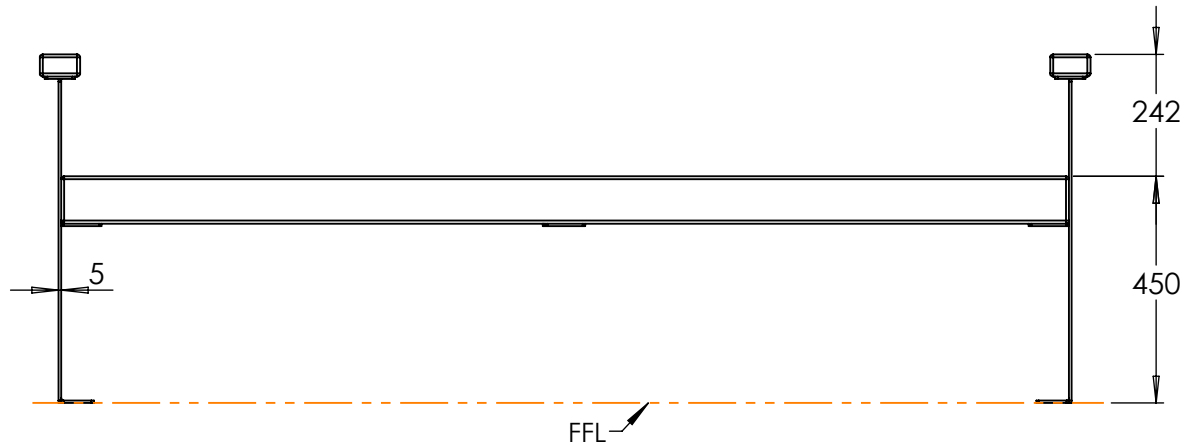
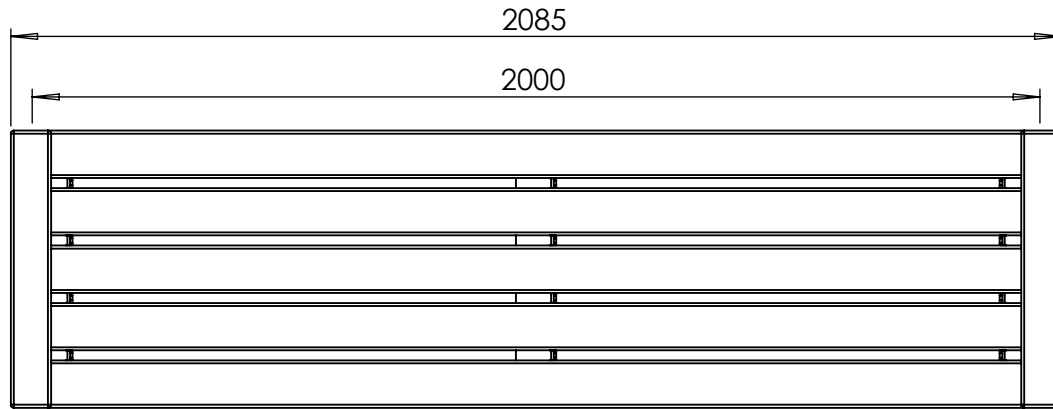
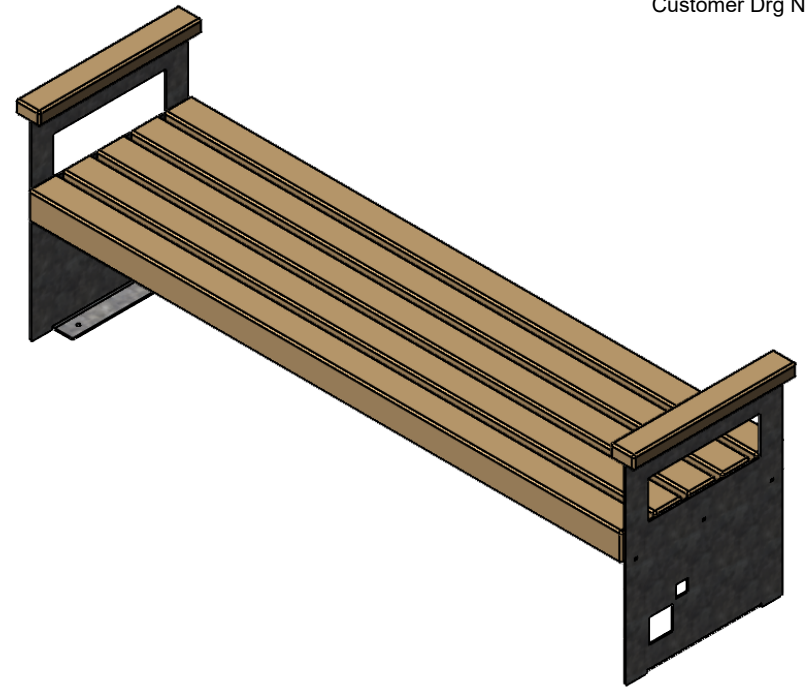

VELOX Rapid Edge™ UK00003507705 / Patent no: GB2600394 / Registered Design - Europe: 008214910 & UK: 90082149100001 Above FFL mm Below FFL mm Quantity -

Agreed Sub-base Material:				Lateral Support:				Product		<p>Logic Manufacture Bespoke™ 01642 373400 specification@logic-bespoke.com</p>
REVISIONS		Drawn By	SA	Linear metre	mm	STAGE	PLATEU BENCH WITH ARMS			
REV.	AMENDMENTS/NOTE	DATE	PM				Project:			
P01	INITIAL ISSUE		Timber	2000X94X94 OPTION DEPENDENT						
			Metal	5mm OPTION DEPENDENT					DWG. NO. XXXX-BXX	
			Finish							
TOLERANCE: All dimensions tolerance +/- 5mm			REV. P01		DO NOT SCALE DRAWINGS		LOGIC MANUFACTURED BESPOKE™ ALL RIGHTS RESERVED		Sheet No. 10 of 14	SIZE A4

Timber Disclaimer: All timbers lose a degree of tanning, some more than others. Timber in an external environment is susceptible to cracking, shelling and moving due to the natural drying process, this does not take away from the durability of the product. In time timber may develop surface discolouration, this is caused by natural mould feeding on the tannins and should disperse as the timber dries and turns silver. Logic are not liable for this natural process and can not be held responsible for any of these natural processes. All products to be installed in conjunction with the supplied installation guide, following the steps & guidance. All Logic products will bear some form of company branding.

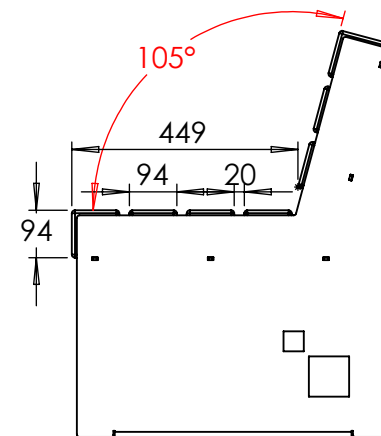
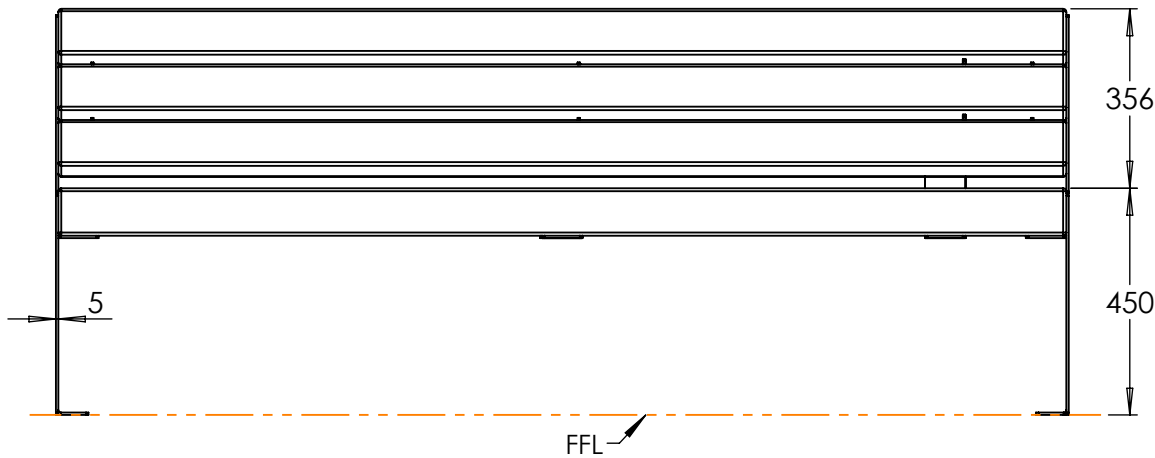
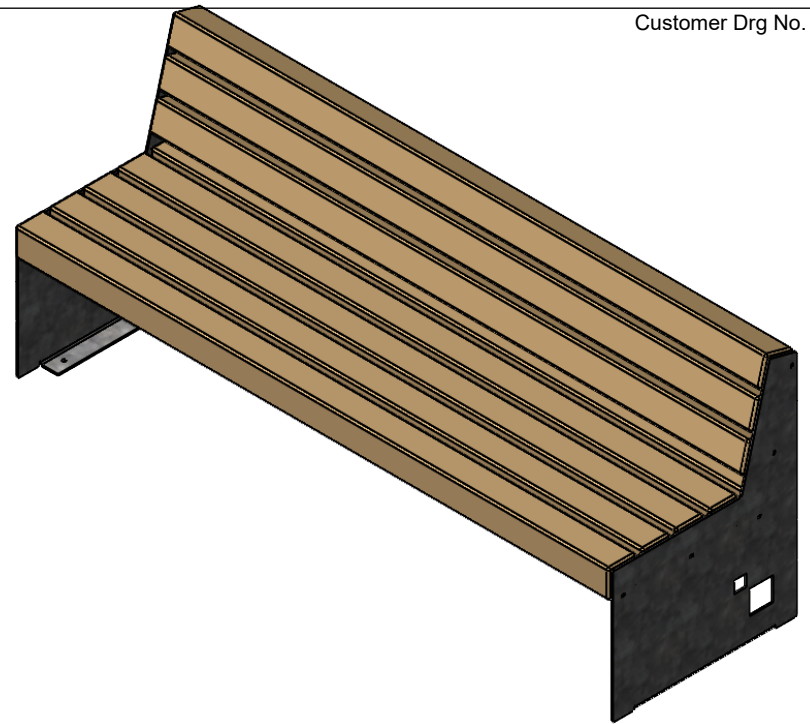
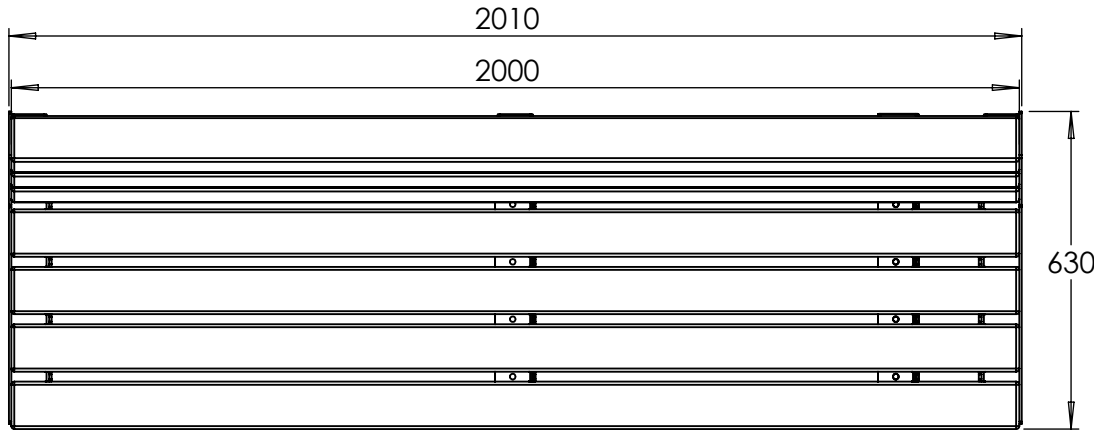

VELOX Rapid Edge™ UK00003507705 / Patent no: GB2600394 / Registered Design - Europe: 008214910 & UK: 90082149100001		Above FFL	mm	Below FFL	mm	Quantity	-
--	--	-----------	----	-----------	----	----------	---

Agreed Sub-base Material: _____ Lateral Support: _____

REVISIONS			Drawn By	SA	Linear metre	mm	STAGE	Product PLATEU SEAT	Project:		
REV.	AMENDMENTS/NOTE	DATE	PM								
P01	INITIAL ISSUE		Timber		2000X94X94 OPTION DEPENDENT					Logic Manufacture Bespoke™ 01642 373400 specification@logic-bespoke.com DWG. NO. XXXX-BXX	
			Metal		5mm OPTION DEPENDENT						Sheet No. 11 of 14 SIZE A4
			Finish								
TOLERANCE: All dimensions tolerance +/- 5mm			REV. P01			LOGIC MANUFACTURED BESPOKE™ ALL RIGHTS RESERVED					

Timber Disclaimer: All timbers lose a degree of tanning, some more than others. Timber in an external environment is susceptible to cracking, shelling and moving due to the natural drying process, this does not take away from the durability of the product. In time timber may develop surface discolouration, this is caused by natural mould feeding on the tannins and should disperse as the timber dries and turns silver. Logic are not liable for this natural process and can not be held responsible for any of these natural processes. All products to be installed in conjunction with the supplied installation guide, following the steps & guidance. All Logic products will bear some form of company branding.

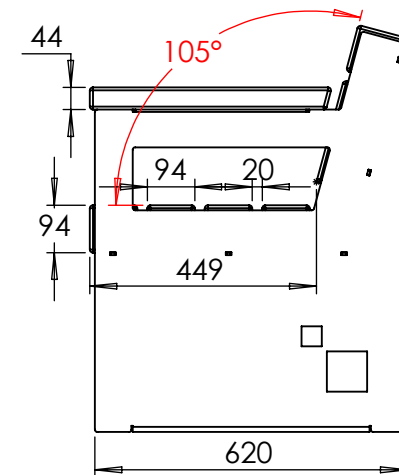
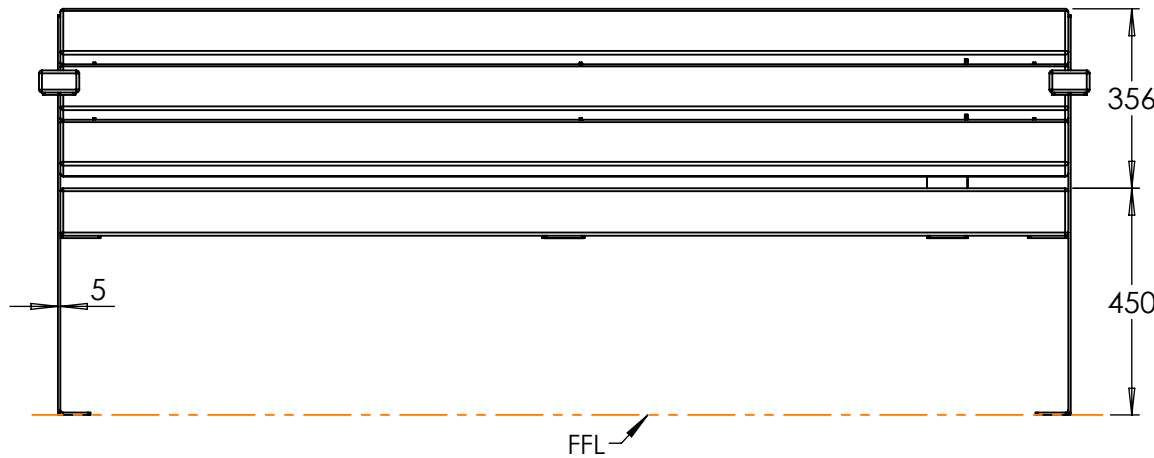
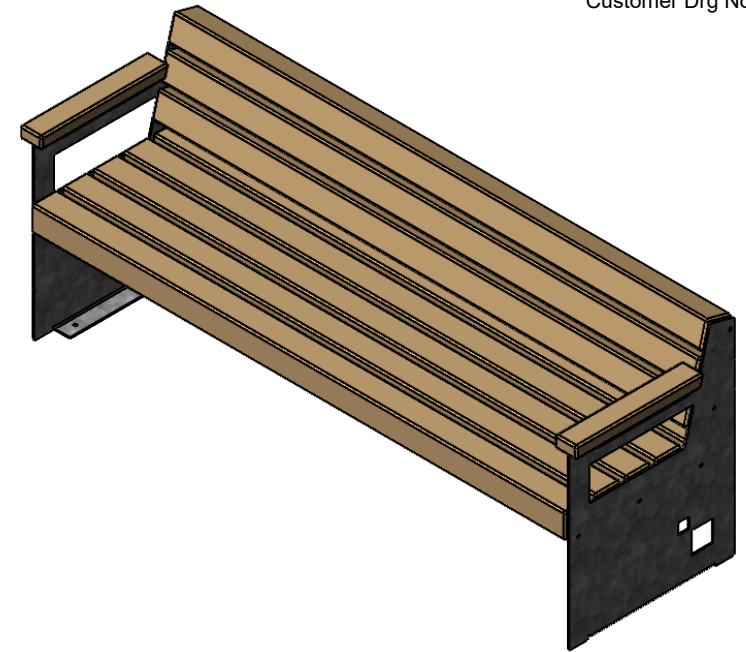
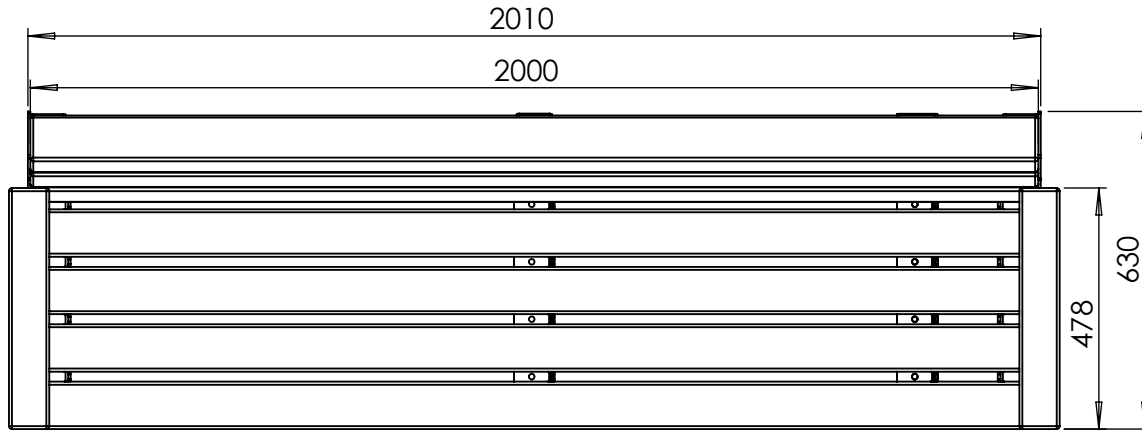

VELOX Rapid Edge™ UK00003507705 / Patent no: GB2600394 / Registered Design - Europe: 008214910 & UK: 90082149100001 | Above FFL | mm | Below FFL | mm | Quantity | -

Agreed Sub-base Material: | Lateral Support:

REVISIONS			Drawn By	SA	Linear metre	mm	STAGE	Product PLATEU SEAT WITH ARMS	Project:	 Logic Manufacture Bespoke™ 01642 373400 specification@logic-bespoke.com	Sheet No.	SIZE
REV.	AMENDMENTS/NOTE	DATE	PM									
P01	INITIAL ISSUE		Timber		2000X94X94 OPTION DEPENDENT					DWG. NO. XXXX-BXX	12 of 14	A4
			Metal		5mm OPTION DEPENDENT							
			Finish									

TOLERANCE: All dimensions tolerance +/- 5mm | REV. P01



LOGIC MANUFACTURED BESPOKE™
ALL RIGHTS RESERVED

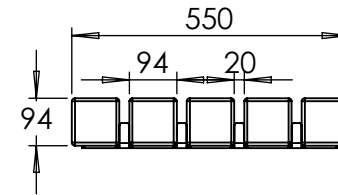
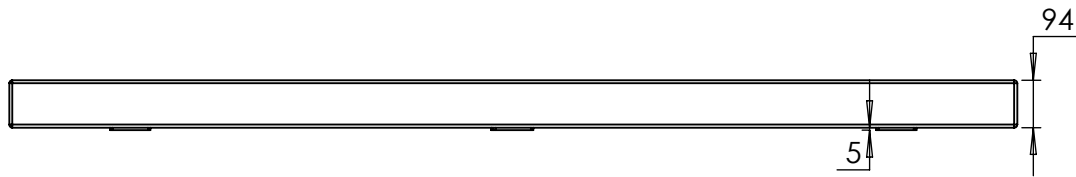
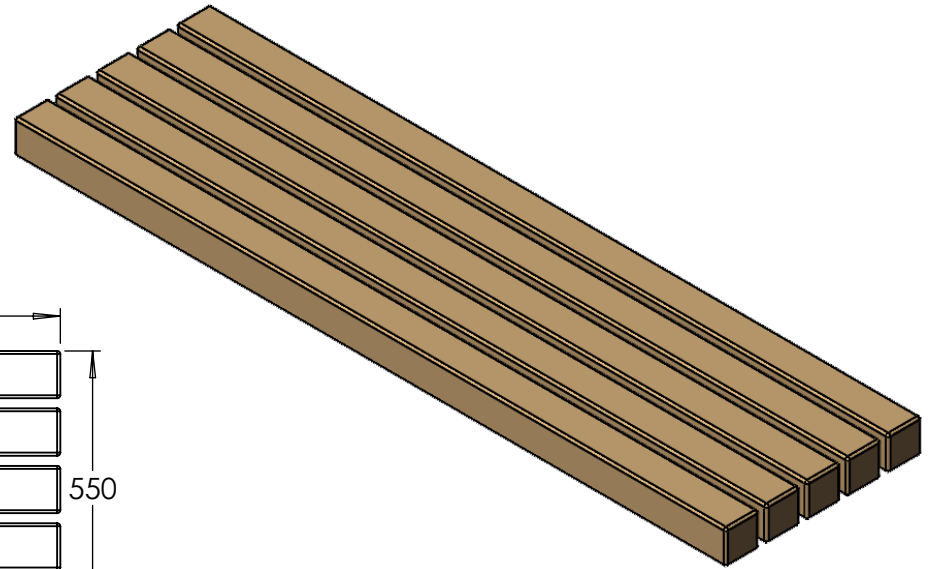
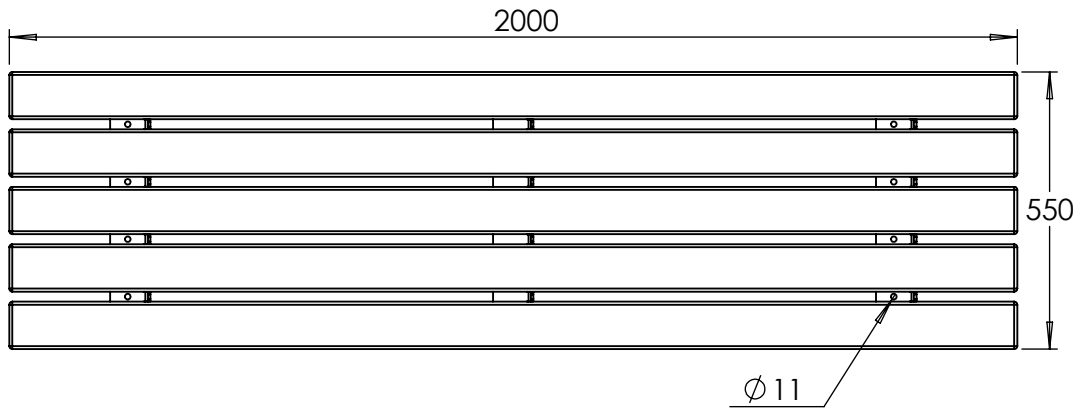

Timber Disclaimer: All timbers lose a degree of tanning, some more than others. Timber in an external environment is susceptible to cracking, shelling and moving due to the natural drying process, this does not take away from the durability of the product. In time timber may develop surface discolouration, this is caused by natural mould feeding on the tannins and should disperse as the timber dries and turns silver. Logic are not liable for this natural process and can not be held responsible for any of these natural processes. All products to be installed in conjunction with the supplied installation guide, following the steps & guidance. All Logic products will bear some form of company branding.



VELOX Rapid Edge™ UK00003507705 / Patent no: GB2600394 / Registered Design - Europe: 008214910 & UK: 90082149100001 | Above FFL | mm | Below FFL | mm | Quantity | -

Agreed Sub-base Material:

Lateral Support:

REVISIONS			Drawn By	SA	Linear metre	mm	STAGE	Product PLATEU BENCH TOPPER	Project:	 Logic Manufacture Bespoke™ 01642 373400 specification@logic-bespoke.com	Sheet No.	SIZE
REV.	AMENDMENTS/NOTE	DATE	PM									
P01	INITIAL ISSUE		Timber		2000X94X94	OPTION DEPENDENT				DWG. NO. XXXX-BXX		
			Metal		5mm	OPTION DEPENDENT						
			Finish									
TOLERANCE: All dimensions tolerance +/- 5mm			REV. P01		 LOGIC MANUFACTURED BESPOKE™ ALL RIGHTS RESERVED							

Timber Disclaimer: All timbers lose a degree of tanning, some more than others. Timber in an external environment is susceptible to cracking, shelling and moving due to the natural drying process, this does not take away from the durability of the product. In time timber may develop surface discolouration, this is caused by natural mould feeding on the tannins and should disperse as the timber dries and turns silver. Logic are not liable for this natural process and can not be held responsible for any of these natural processes. All products to be installed in conjunction with the supplied installation guide, following the steps & guidance. All Logic products will bear some form of company branding.

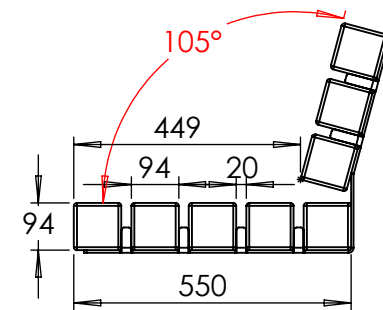
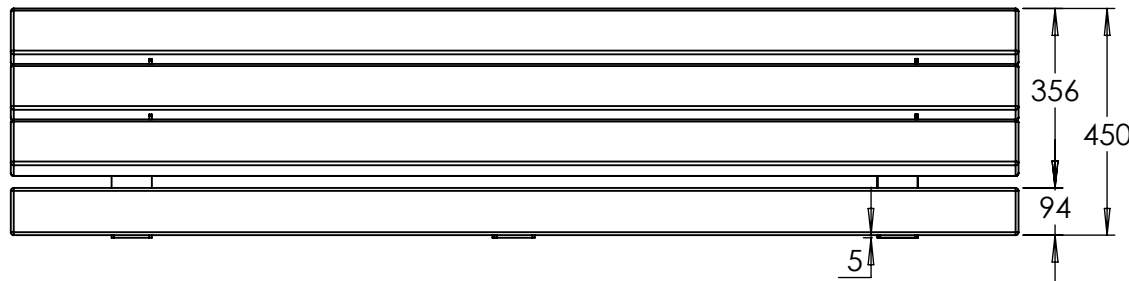
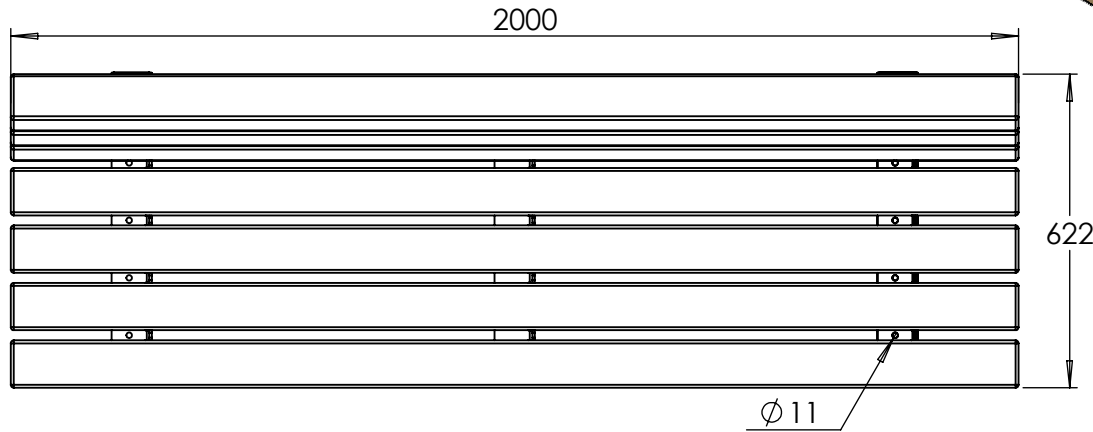
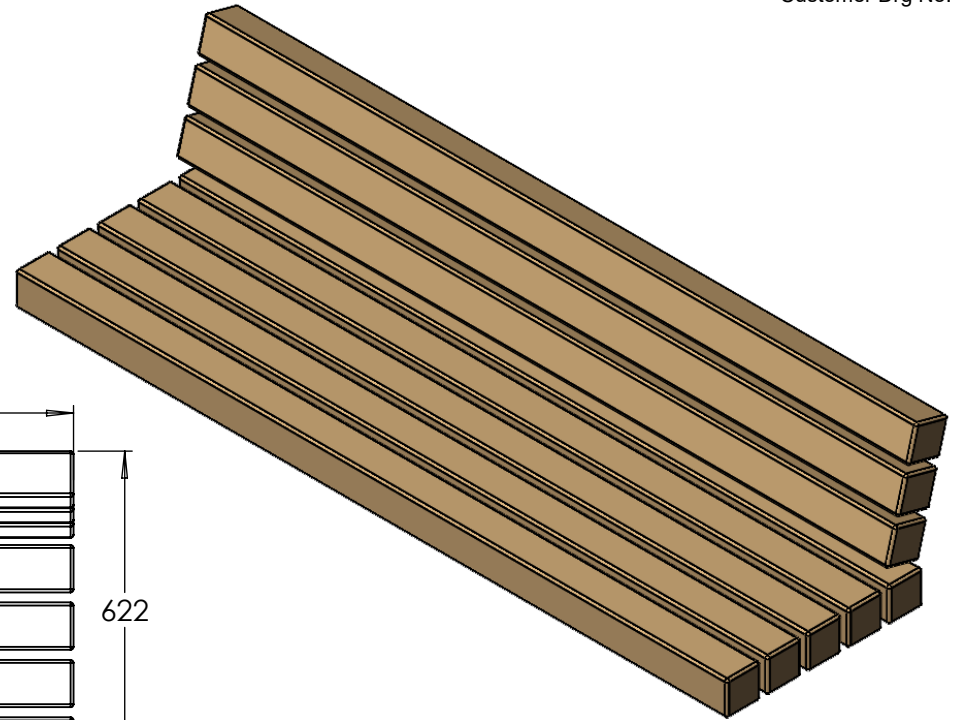

VELOX Rapid Edge™ UK00003507705 / Patent no: GB2600394 / Registered Design - Europe: 008214910 & UK: 90082149100001 | Above FFL | mm | Below FFL | mm | Quantity | -

Agreed Sub-base Material: | Lateral Support:

REVISIONS			Drawn By	SA	Linear metre	mm	STAGE	Product PLATEU SEAT TOPPER	Project:		
REV.	AMENDMENTS/NOTE	DATE	PM								
P01	INITIAL ISSUE		Timber		2000X94X94 OPTION DEPENDENT						
			Metal		5mm OPTION DEPENDENT						
			Finish								
TOLERANCE: All dimensions tolerance +/- 5mm			REV. P01				LOGIC MANUFACTURED BESPOKE™ ALL RIGHTS RESERVED		DWG. NO. XXXX-BXX	Sheet No. 14 of 14	SIZE A4

Timber Disclaimer: All timbers lose a degree of tanning, some more than others. Timber in an external environment is susceptible to cracking, shelling and moving due to the natural drying process, this does not take away from the durability of the product. In time timber may develop surface discolouration, this is caused by natural mould feeding on the tannins and should disperse as the timber dries and turns silver. Logic are not liable for this natural process and can not be held responsible for any of these natural processes. All products to be installed in conjunction with the supplied installation guide, following the steps & guidance. All Logic products will bear some form of company branding.